

Recent Development of The Joint Crediting Mechanism (JCM)

November 2014
Government of Japan

Current status of the JCM implementation

Partner countries of the JCM

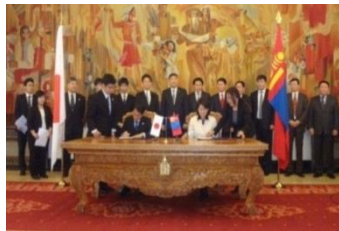

Mongolia
Jan. 8, 2013
(Ulaanbaatar)



Bangladesh
Mar. 19, 2013
(Dhaka)



Ethiopia
May 27, 2013
(Addis Ababa)

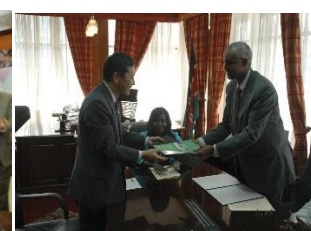

Kenya
Jun. 12, 2013
(Nairobi)



Maldives
Jun. 29, 2013
(Okinawa)



Viet Nam
Jul. 2, 2013
(Hanoi)

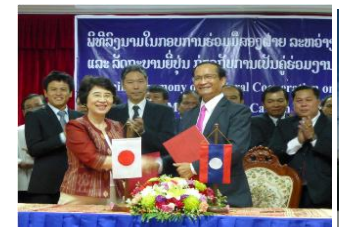

Lao PDR
Aug. 7, 2013
(Vientiane)



Indonesia
Aug. 26, 2013
(Jakarta)

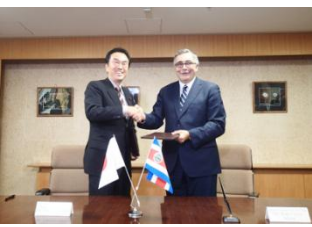

Costa Rica
Dec. 9, 2013
(Tokyo)



Palau
Jan. 13, 2014
(Ngerulmud)



Cambodia
Apr. 11, 2014
(Phnom Penh)



Mexico
Jul. 25, 2014
(Mexico City)

- JCM website has been established <URL: <https://www.jcm.go.jp/>>
- JCM registry will be established and start its operation in FY2015
- 5 methodologies have already been approved
- One project has already been registered

- Introducing high efficiency centrifugal chiller for the factories etc., which is characterized by:
 - ✓ Non ozone-depleting refrigerant, HFC 245fa
 - ✓ COP more than 6.0
- The existing old type chiller whose COP is approximately 5.0 is assumed to be used continuously in general, except for the JCM project implementation, in order to avoid new investment on replacement/installation.



The COP of the chiller eligible under the methodology is higher than any of commercially available chillers in Indonesia, thus eligible as a JCM project

■ High Efficiency Centrifugal Chiller

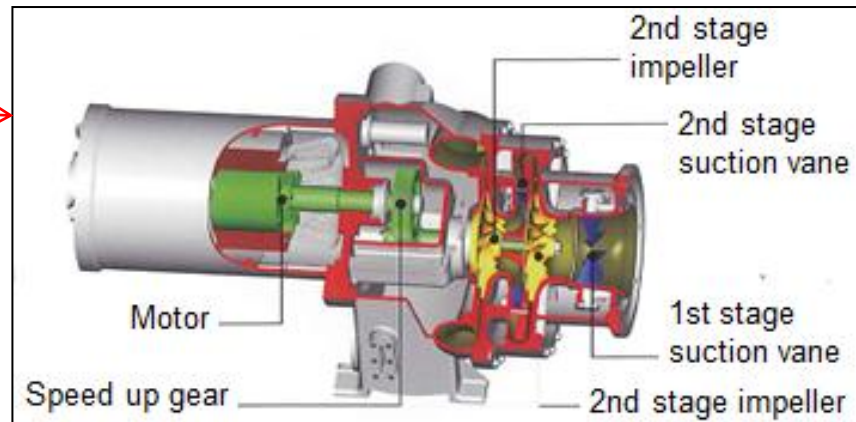

- Emission reductions are calculated based on the difference between the amount of project power consumption and reference power consumption which is derived from the ratio of the project COP to the reference COP.
- The reference COP is conservatively set as a default value by taking maximum COP of commercially available chillers in the certain cooling capacity.

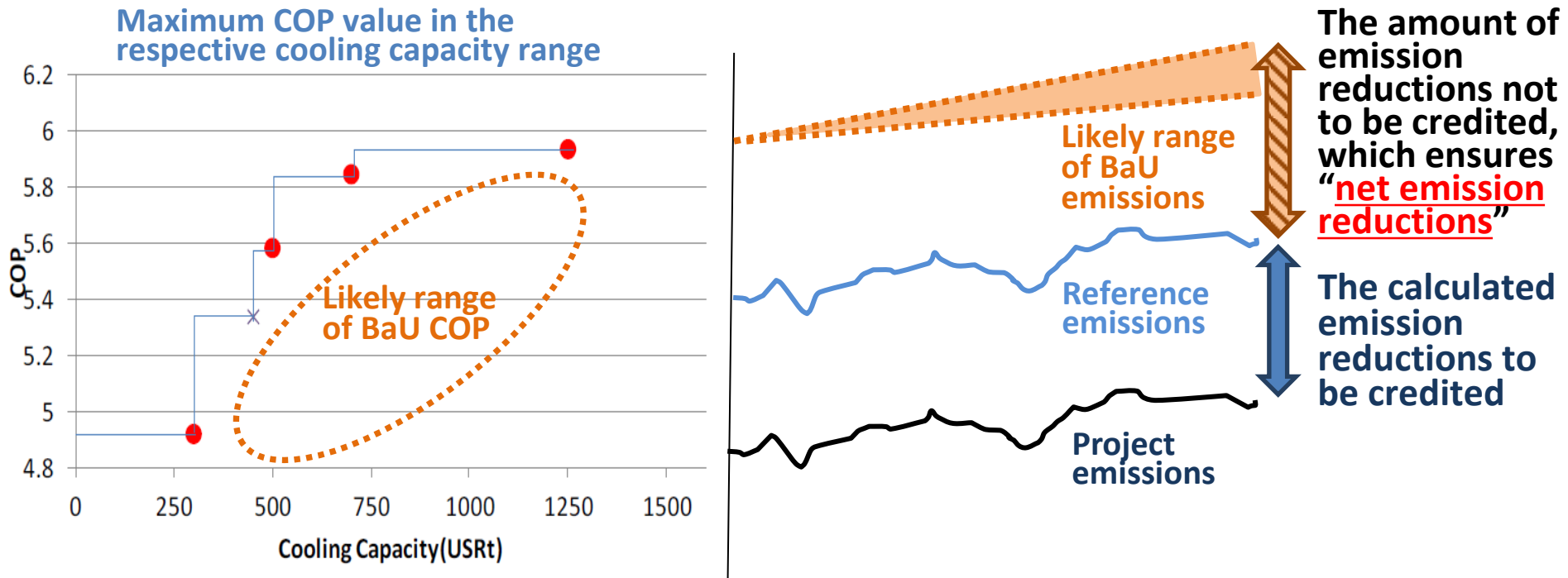

- Monitoring is simplified as only a single parameter is to be monitored:
 - ✓ Power consumption of project chiller

- The project utilizes waste heat from the cement production facility by waste heat recovery (WHR) system to generate electricity.
- Only 1 WHR system has been installed to 1 plant out of existing 25 plants in Indonesia.



WHR system in cement industry is not a commonly installed technology in Indonesia, thus eligible as a JCM project

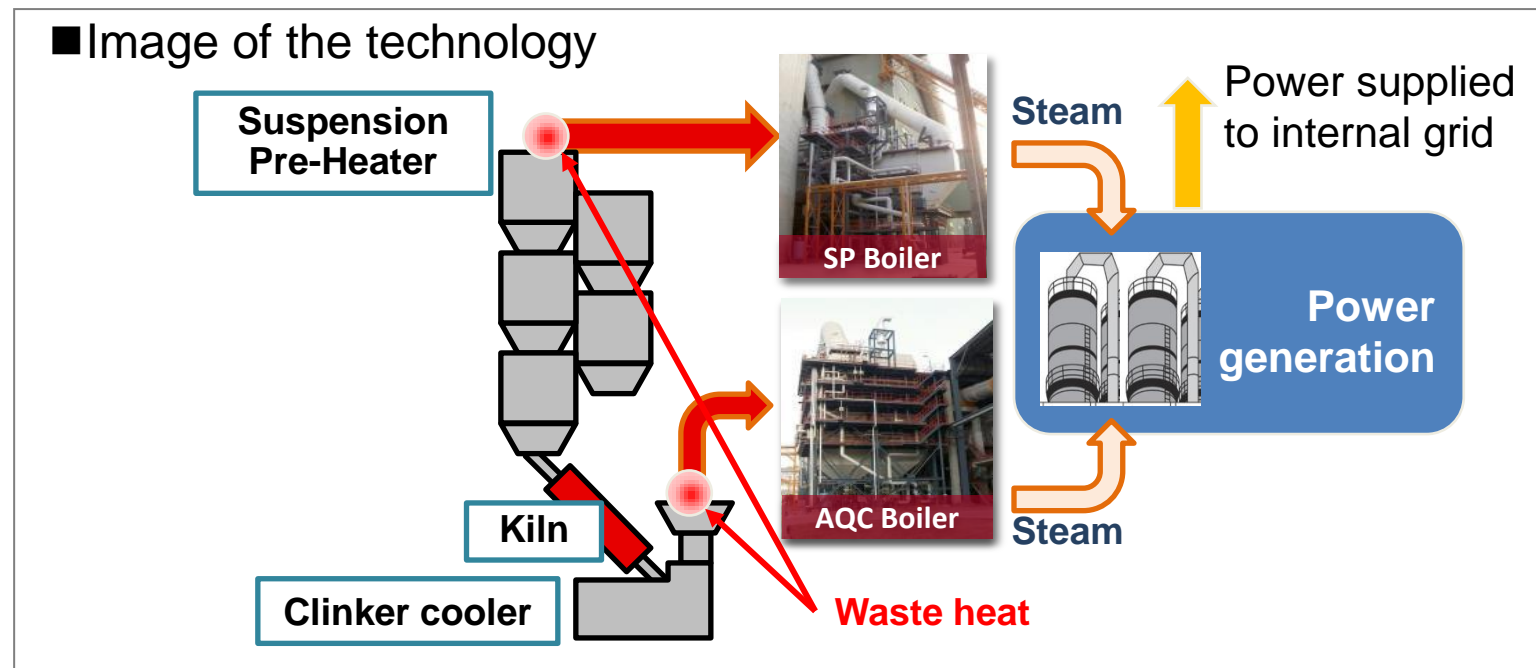

- Emission reductions are calculated based on the difference between the quantity of electricity supplied by the WHR system to the cement facility and the calculated maximum power consumption of the WHR system.
- The maximum power consumption of the WHR system is derived from the total maximum rated capacity of equipments of the WHR system assuming their operation of 24h/day.

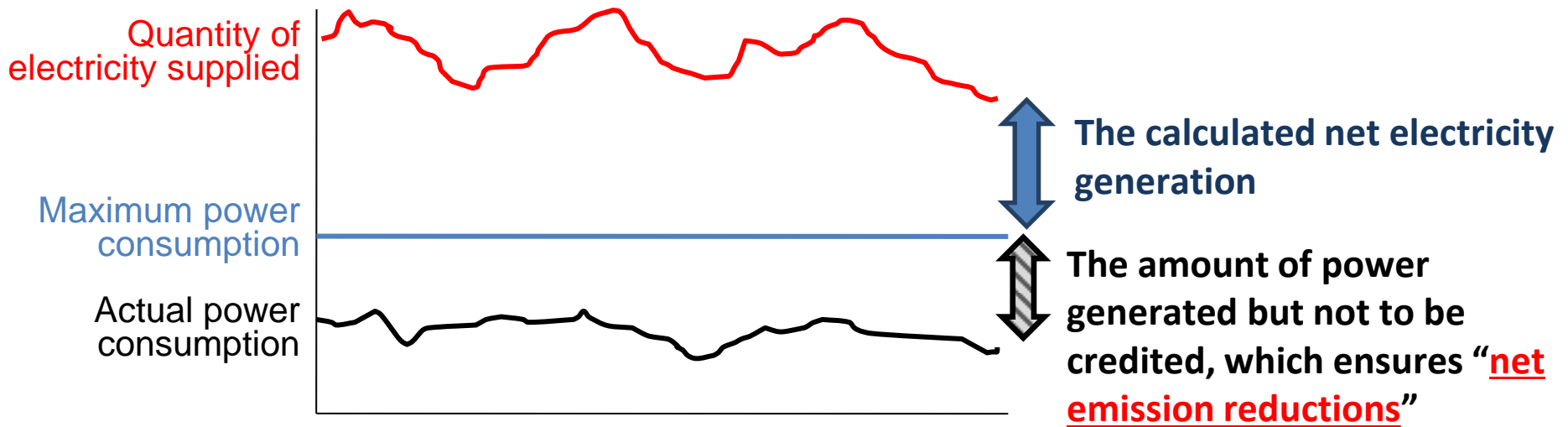

- Monitoring is simplified as only two parameters are to be monitored:
 - ✓ The quantity of the electricity supplied from the WHR system to the cement production facility
 - ✓ The number of days during a monitoring period